

## Male Pipe (N.P.T.F.) X Male J.I.C. (37°)

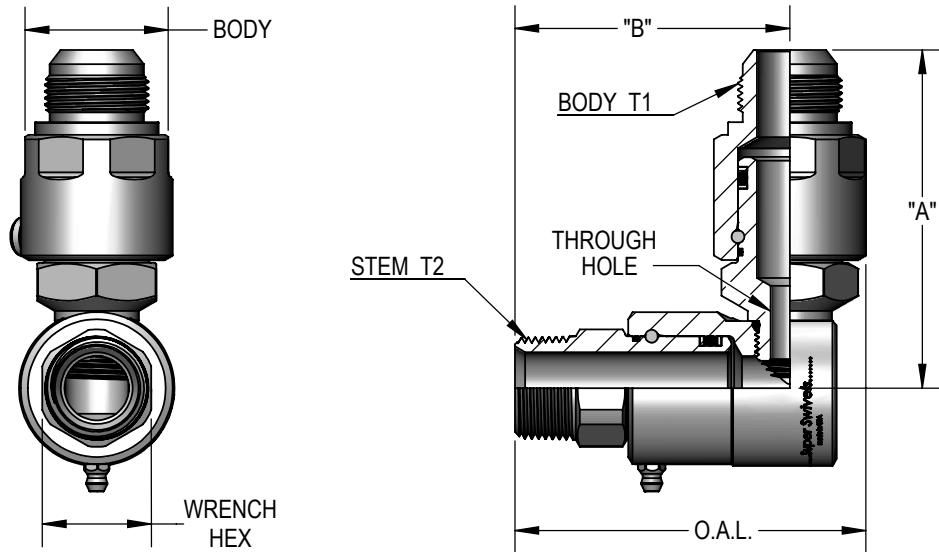

Not Available  
In Stainless Steel!

PART NUMBER	O.A.L.	DIM. B	BODY	WRENCH/HEX	BODY T1	STEM T2	DIM. A	MAX. P.S.I.G.	THROUGH HOLE
9 DP 4 MP 25 X MJ 4	2.640	2.130	1.000	0.625	7/16-20 U.N.	1/4-18 N.P.T.F.	2.689	5000	0.172
9 DP 4 MP 38 X MJ 6	2.720	2.210	1.000	1.000	9/16-18 U.N.	3/8-18 N.P.T.F.	2.807	5000	0.250
9 DP 8 MP 50 X MJ 8	3.360	2.620	1.375	1.000	3/4-16 U.N.	1/2-14 N.P.T.F.	3.103	5000	0.297
9 DP 8 MP 50 X MJ 10	3.360	2.620	1.375	1.000	7/8-14 U.N.	1/2-14 N.P.T.F.	3.253	5000	0.297
9 DP 12 MP 75 X MJ 12	3.626	2.760	1.560	1.125	1 1/16-12 U.N.	3/4-14 N.P.T.F.	3.465	4500	0.391
9 DP 16 MP 100 X MJ 16	4.420	3.462	1.810	1.375	1 5/16-12 U.N.	1-11 1/2 N.P.T.F.	4.260	4000	0.484
9 DP 20 MP 125 X MJ 20	4.973	3.795	2.188	1.750	1 5/8-12 U.N.	1 1/4-11 1/2 N.P.T.F.	4.796	4000	0.718
9 DP 24 MP 150 X MJ 24	5.890	4.620	2.375	2.000	1 7/8-12 U.N.	1 1/2-11 1/2 N.P.T.F.	5.510	4000	0.844

## Male J.I.C. (37°) X Male J.I.C. (37°)

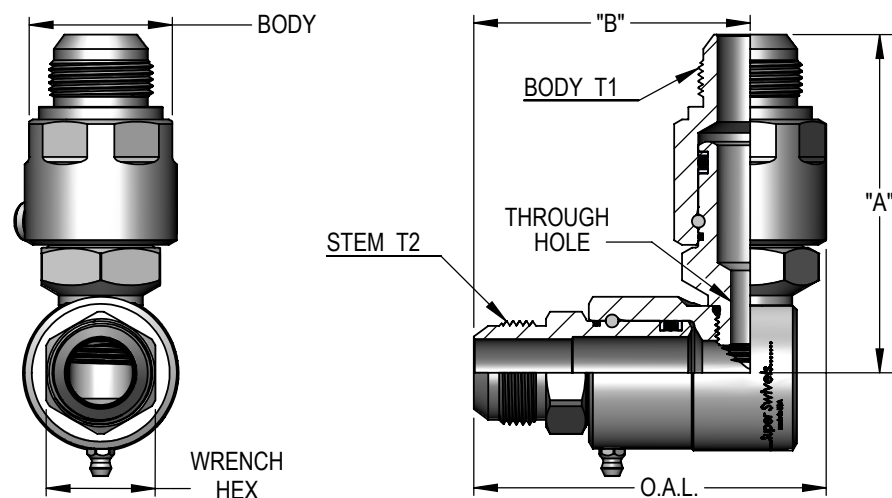

Not Available  
In Stainless Steel!

PART NUMBER	O.A.L.	DIM. B	BODY	WRENCH/HEX	BODY T1	STEM T2	DIM. A	MAX. P.S.I.G.	THROUGH HOLE
9 DP 4 MJ 4 X MJ 4	2.837	2.325	1.000	0.625	7/16-20 U.N.	7/16-20 U.N.	2.689	5000	0.172
9 DP 4 MJ 6 X MJ 6	2.922	2.345	1.000	0.625	9/16-18 U.N.	9/16-18 U.N.	2.689	5000	0.250
9 DP 8 MJ 8 X MJ 8	3.168	2.523	1.375	1.000	3/4-16 U.N.	3/4-16 U.N.	3.103	5000	0.297
9 DP 8 MJ 10 X MJ 10	3.416	2.623	1.375	1.000	7/8-14 U.N.	7/8-14 U.N.	3.253	5000	0.297
9 DP 12 MJ 12 X MJ 12	3.751	2.885	1.560	1.125	1 1/16-12 U.N.	1 1/16-12 U.N.	3.465	4500	0.391
9 DP 16 MJ 16 X MJ 16	4.441	3.482	1.810	1.375	1 5/16-12 U.N.	1 5/16-12 U.N.	4.260	4000	0.484
9 DP 20 MJ 20 X MJ 20	5.013	3.835	2.188	1.750	1 5/8-12 U.N.	1 5/8-12 U.N.	4.796	4000	0.718
9 DP 24 MJ 24 X MJ 24	5.980	4.710	2.375	2.000	1 7/8-12 U.N.	1 7/8-12 U.N.	5.510	4000	0.844